

MINI PNEUMATIC PUMPSETS DOP 06 and DOP 10

Mini pneumatic pumpsets are independent vacuum units, fed exclusively by compressed air and featuring very small sizes. They are composed of:

- A small welded sheet steel tank.
- A compressed air-operated vacuum generator.
- A pneumatic vacuum switch for adjusting the vacuum level.
- A vacuum gauge for a direct reading of the vacuum level.
- A manual valve for vacuum interception.
- A suction filtre with an FC paper cartridge.
- A pressure adjuster equipped with filtre.
- A pneumatic activation valve for the vacuum generator supply.
- A sleeve valve for compressed air interception.

- for compressed air interception for draining condensation from the tank. the vacuum level in the tank, previously set with the vacuum switch, is automatically maintained.

Mini pneumatic pumpsets are suited for equipping small fixed and mobile working units that require vacuum, such as:

- Trolleys with vacuum cups for fixing and transporting glass and crystals.
- Vacuum clamping systems for ski maintenance, to drill or pantograph marble, to polish pewter, copper or silver objects, etc.
- Tackles with cups for lifting television sets and other household appliances, for the insertion of glass in the window fittings, for feeding sheet metal to presses, etc.

Mini pneumatic pumpsets require no electricity, only compressed air at a 4 ÷ 6 bar (g) pressure. For this feature they are recommended in hazardous environments where an ignition source would be dangerous.

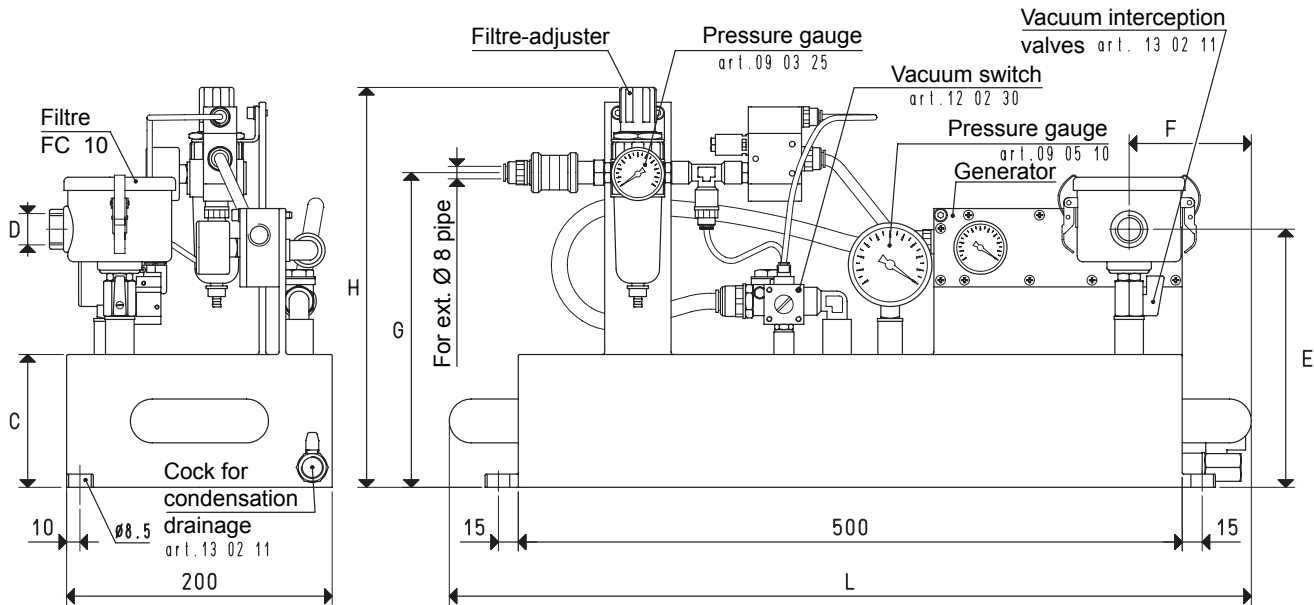

Art.	Tank	Generator	Pneumatic device	C	D	E	F	G	H	L	Weight
	Litres	art.	art.				∅				Kg
DOP 06 PVP 12 MX	6	PVP 12 MX	DOP 06 90	60	G3/8"	150	95	180	260	620	12.7
DOP 06 PVP 25 MX	6	PVP 25 MX	DOP 06 90	60	G3/8"	150	95	180	260	620	13.0
DOP 10 PVP 12 MX	10	PVP 12 MX	DOP 06 90	100	G3/8"	210	95	240	300	620	12.9
DOP 10 PVP 25 MX	10	PVP 25 MX	DOP 06 90	100	G3/8"	210	95	240	300	620	13.2

Conversion ratio: inch = $\frac{\text{mm}}{25.4}$; pounds = $\frac{\text{g}}{453.6}$ = $\frac{\text{Kg}}{0.4536}$

GAS-NPT thread adapters available at page 1.117

8.97

MINI PNEUMATIC PUMPSETS DOP 20

The distinctive feature of this mini pumpset, apart from the tank volume, is the installed vacuum generator.

The vacuum generator of the PVP... MDX ES range, in fact, is equipped with an energy saving device which allows automatically maintaining the preset vacuum level inside the tank. The other accessories, except for the vacuum switch and the pneumatic activation valve for the vacuum generator supply, are the same as those installed on DOP 06 and DOP 10. They are used as the previously described mini pneumatic pumpsets.

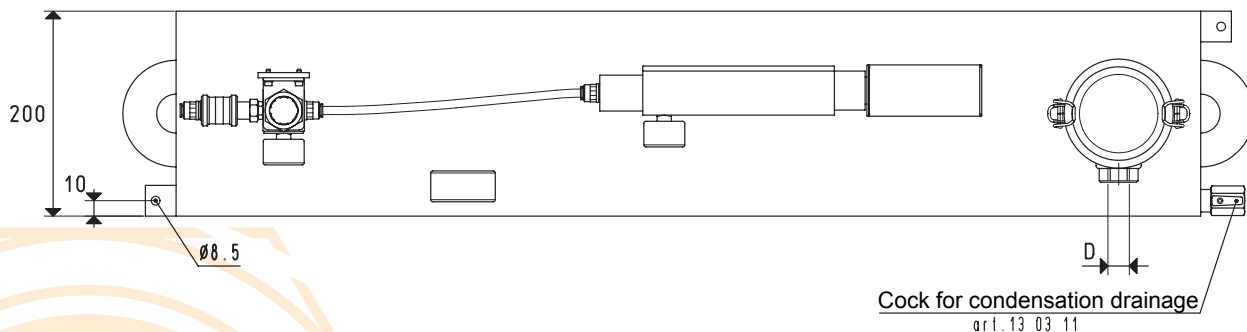
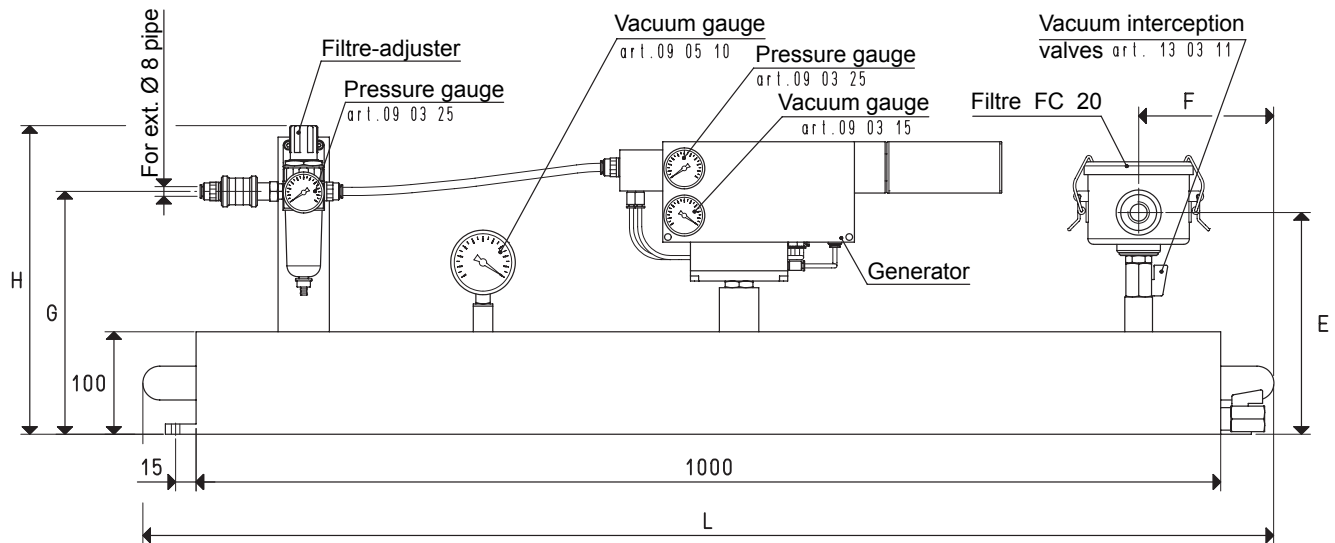
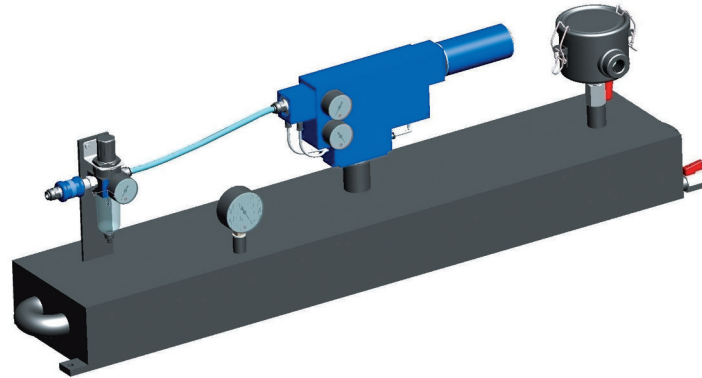

Art.	Tank	Generator	Pneumatic device	D	E	F	G	H	L	Weight
	Litres	art.	art.	Ø						Kg
DOP 20 PVP 25 MDX	20	PVP 25 MDX ES	DOP 20 90	G1/2"	225	135	270	340	1110	20.6
DOP 20 PVP 35 MDX	20	PVP 35 MDX ES	DOP 20 90	G1/2"	225	135	270	340	1110	20.7

8.98

Conversion ratio: inch = $\frac{\text{mm}}{25.4}$, pounds = $\frac{\text{g}}{453.6} = \frac{\text{Kg}}{0.4536}$

GAS-NPT thread adapters available at page 1.117

3D drawing available at www.vuotecnica.net